

TRIPLETT

Model 310-TEL *Type 3* **Hand-Sized VOM** *Instruction Manual*



 **TRIPLETT**

TABLE OF CONTENTS _____

| | |
|--|-----------|
| SAFETY RULES | 3 |
| INTRODUCTION | 9 |
| SPECIFICATIONS | 10 |
| GENERAL INSTRUCTIONS | 12 |
| <i>Test Leads</i> | <i>12</i> |
| <i>Range Selection</i> | <i>12</i> |
| <i>Scale Selection</i> | <i>13</i> |
| <i>Polarity Selection</i> | <i>13</i> |
| <i>Changing Settings</i> | <i>13</i> |
| <i>Zero Adjustment</i> | <i>13</i> |
| <i>Other Considerations</i> | <i>14</i> |
| <i>Care</i> | <i>14</i> |
| CONTROL LOCATION DIAGRAM | 15 |
| DC VOLTAGE MEASUREMENTS | 16 |
| AC VOLTAGE MEASUREMENTS | 18 |
| RESISTANCE MEASUREMENTS | 20 |
| DC CURRENT MEASUREMENTS | 22 |
| MEASURING OUTPUT VOLTS (dB) | 24 |
| OPERATION CHART | 26 |
| ACCESSORIES | 27 |
| MAINTENANCE | 28 |
| TRIPLETT LIMITED WARRANTY | 30 |

SAFETY RULES • WARNING

This tester has been designed with your safety in mind. However, no design can completely protect against incorrect use. Electrical circuits can be dangerous and/or lethal when lack of caution or poor safety practices are used.

WARNING

This meter is NOT to be used to measure High Energy circuits (power circuitry fused at greater than 4KW, such as distribution circuits, power entrance circuits, etc.) or circuits classified by CE as CATEGORY III (CAT III).

SAFETY RULES AND WARNINGS _____

- *Read all instructions in this manual before using this meter.*
- *Prior to using this meter in any situation which could result in injury to the user, in order to verify that the meter is functional and producing a valid reading, test the meter on a circuit(s) known to have potentials equivalent to the potential that is to be measured. For example, before using the meter to determine if an AC power line is energized with 120VAC, test the meter on a line known to be energized with 120VAC.*
- *Do not exceed the maximum voltage limitations of this meter (see product specifications). Doing so may damage the meter and/or injure the user.*
- *When using this meter in schools and workshops, responsible teachers or skilled personnel must control the usage of this meter.*
- *Follow the recommendations of any Trade Organizations or Regulatory Agencies whose scope encompasses the use of this meter.*

- *Do not use this meter with its battery cover open, its rear case open, or with parts removed.*
- *Do not open this meter for maintenance without first disconnecting the test leads from all external circuitry.*
- *Repairs and maintenance must only be carried out by qualified service personnel or qualified electricians / technicians who know the dangers of, and the safety rules applicable to this type of equipment.*
- *Use caution when measuring circuits containing capacitors. Capacitors can store dangerous levels of electricity, even when the circuitry which they are in has been disconnected from its power source.*
- *Use caution when working with voltages above 25 volts AC or 35 volts DC. Such voltages may cause a life threatening electrical shock.*
- *This meter is not for use by children.*
- *Always set the meter to the appropriate range, mode or polarity before connecting it to the circuitry to be tested.*
- *Never attempt to make voltage measurements with the Function switch set to any of the OHMS or MA ranges. Doing so may damage the meter and/or injure the user.*
- *Do not rotate the Range switch or move the Polarity switch with the test leads connected to the circuitry to be tested. Doing so may damage the meter and/or injure the user.*
- *Before using the meter, examine both the meter and the test leads for damage. Do not use the meter if damage (damaged insulation, exposed metal, cracked case, burnt smell, etc.) is evident.*
- *Do not use this meter to make measurements in adverse environments such as rain, snow, fog, or locations with steam, explosive gases or dusts. Doing so may damage the meter and/or injure the user.*

- *Make sure both test leads are fully inserted into their respective input jacks (Black lead into COM and Red lead into V•O•M). A loose test lead may cause the user to misinterpret the dangers present (the meter may read Zero when dangerous voltage is present) or the loose lead may accidentally short to other circuitry or shock the user.*
- *Do not use the meter if either the meter or the test leads are wet, either from exposure to the weather, or after cleaning the case of the meter. Doing so may cause injury to the user.*
- *Avoid usage near strong magnetic fields (magnets, loudspeakers, transformers, motors, coils, relays, contactors, electromagnets, etc.). The meter may display readings that are in error, causing the user to misinterpret the hazards present. For example, the meter may indicate a low voltage when high voltages are actually present.*
- *Avoid usage near strong electrostatic fields (high voltage power lines, televisions, computer monitors, etc.). The meter may display readings that are in error, causing the user to misinterpret the hazards present. For example, the meter may indicate a low voltage when high voltages are actually present.*
- *Avoid usage near strong RF fields (radio or television transmitters, etc.). The meter may display readings that are in error, causing the user to misinterpret the hazards present. For example, the meter may indicate a low voltage when high voltages are actually present.*
- *Do not touch the tips of the test leads when making a measurement. Do not touch live circuitry when making a measurement.*
- *Do not apply more than 1200 volts DC/AC rms sine between the test leads and the earth ground. Doing so may damage the meter and/or injure the user.*
- *If there is any doubt about the condition of the meter (i.e. safe vs unsafe), remove the meter from service and secure it in a location that will prevent its unintentional use.*

- *Do not use the meter if it does not appear to work correctly on all ranges and in all modes.*
- *Do not use the meter if it has undergone long-term storage under unfavorable conditions.*
- *Do not use the meter if it may have been damaged in transport.*
- *Do not attempt immediate use of the meter when bringing it from a cold environment to a warm environment. Condensation of water, inside and outside of the meter, may produce dangerous measuring conditions. Allow the meter to warm to room temperature before using.*
- *Do not use meter in condensing atmospheres. That is, do not use meter in conditions where ambient temperature and humidity could cause condensation of water inside of meter. Doing so may cause injury to the user.*
- *Use caution when attempting to evaluate if a dangerous voltage is present. The meter will not read AC voltage if it is set to DC. For example, if the meter is set to 300VDC, it will not measure a dangerous AC voltage, even if the probes are inserted into a household AC wall outlet.*
- *Do not touch the metallic portion of one test lead if the other test lead is connected to a live circuit. The current from the live circuit may pass through the meter and appear on the unconnected test lead. Failure to observe this warning may result in user injury.*
- *Remove the battery when the meter may be left unused for longer than 1 month. Chemical leakage from the battery could damage the meter, leading to user injury.*
- *Do not use the meter if there is evidence of chemical leakage from the battery. Leakage could damage meter and lead to injury of user.*
- *Do not modify the meter. Changing the design may make the meter unsafe and may result in injury to the user.*

- *Do not mistake a downscale reading as an indication that no potential is present. Dangerous potentials may be present that may result in user injury.*
- *When replacing the battery, dispose of the depleted battery in accordance with any prevailing safety or environmental regulations.*
- *A static charge on the face of the meter may cause the meter to produce inaccurate readings, which could lead to user injury. This condition is usually observed in dry climates, when the face of the meter is rubbed with a cloth. Apply Antistat solution, or mild detergent, to the face of the meter to dissipate the static charge.*

READ THE MANUAL _____

Read this Instruction Manual carefully and completely.

Voltages and currents within the capability of this test equipment can be hazardous. Follow the instructions in this manual for every measurement. Read and understand the general instructions before attempting to use this tester. Do not exceed the limits of the tester.

SAFETY CHECK _____

Double check the switch setting and lead connections before making measurements. Are you following all of the instructions?

Disconnect the tester or turn off the power before changing switch positions. Do not connect to circuits with voltage present when switch is in any ohms or current position.

When replacing fuses, use only specified type fuses and insert in correct fuse holder.

DO NOT TOUCH _____

Do not touch exposed wiring, connections or other “live” parts of an electrical circuit. If in doubt, check the circuit first for voltage before touching it.

Turn off the power to a circuit before connecting test probes to it. Be sure there is no voltage present before you touch the circuit. Do not use cracked or broken test leads.

HIGH VOLTAGE IS DANGEROUS _____

Always start with the power off. Be sure there is no voltage present before making connections to the circuit.

Don’t touch the tester, its test leads, or any part of the circuit while it is on.

Before disconnecting the tester, turn the circuit off and wait for the meter to return to “zero.”

DISTRIBUTION CIRCUITS PACK A PUNCH _____

In high energy circuits such as distribution transformers and bus bars, dangerous arcs of explosive nature can occur if the circuit is shorted. If the tester is connected across a high energy circuit when set to a low resistance range, a current range, or any other low impedance range, the circuit is virtually shorted.

Special equipment designed for use with these circuits is available. Contact a qualified person for assistance before attempting to make measurements on any high energy circuit.

SAFETY IS NO ACCIDENT

INTRODUCTION

The Triplet Model 310-TEL is a handy hand-sized VOM with all the versatility and performance of larger, more expensive bench-size models. It offers diode overload protection against damage to the meter movement caused by accidental overloads. A fuse is used to protect the RX1 range. The fuse and batteries can be easily replaced by removing the back cover.

Small enough to be carried in your tool box, glove compartment, brief case, or shirt pocket, the Model 310-TEL allows you to have 20,000 ohms per volt DC and 5,000 ohms per volt AC sensitivity wherever you need it.

A convenient Polarity Reversing Switch electrically reverses the test lead connections, correcting accidental downscale readings and permitting "capacitive kick" readings on the Ohmeter ranges.

Versatility and readability have not been sacrificed in order to provide a portable VOM. The Model 310-TEL offers 16 different ranges that can be easily read on only 3 clearly defined scale areas. A single selector switch allows you to switch easily from range to range and function to function.

SPECIFICATIONS

DC Volts

Ranges: 0-3, 15, 60, 300 (20,000 ohms per volt)

Accuracy: $\pm 3\%$ of full scale value

AC Volts

Ranges: 0-3, 15, 60, 300 (5,000 ohms per volt)

Accuracy: $\pm 4\%$ of full scale value
(on 60Hz sine wave at 77° F)

Ohms

Ranges: 0-20K, 200K, 2 Meg, 20 Meg
(200, 2K, 20K, 200K @ center scale)

Accuracy: $\pm 3\%$ of DC scale length
(with fully charged battery)

Ohmmeter Specifications:

| | Range | | | |
|-------------------------------|------------------|-------------------|--------------------|-------------------|
| | <u>X1</u> | <u>X10</u> | <u>X100</u> | <u>X1K</u> |
| Max Voltage (Volts) | 1.6 | 1.6 | 1.6 | 14.0 |
| Max Current (mA) | 8.0 | 0.8 | .08 | .07 |
| Max. Power (mW) | 3.2 | .32 | .032 | .245 |

DC Milliamperes

Ranges: 0-.6, 6, 60, 600

Accuracy: $\pm 3\%$ of full scale value

Burden Voltage (@ full scale):

Approx. 330mV on 600mA range
Approx. 250mV on other ranges

Meter

50 μ A - 250 mV (Pivot and Jewel)

Overload Protection

Meter movement protected by diodes.

RX1 range protected by fuse.

Voltage ranges protected by high impedance.

Polarity Reversal

The Polarity Switch reverses the polarity of the jacks on all ranges.

Test Lead Polarity

DC Voltage: Lead connected to V•O•M jack is positive with polarity reversal switch in + position.

DC Current: Lead connected to V•O•M jack is positive with polarity reversal switch in + position.

Ohms: Positive battery of Ohmmeter is connected to the V•O•M jack with polarity reversal switch in + position.

Batteries

One 1.5 volt N-cell (NEDA 910) (PN: 37-21)

One 12 volt Eveready A23 (PN: 37-60)

Fuse

1/16A (PN: 3207-112)

Weight

Approximately 14 oz.

Accessories supplied with Model 310-TEL

- 1. Test leads w/Screw-on Alligator clips (PN: 79-153)*
- 2. Batteries: One 1.5V and One 12V*
- 3. Instruction Manual (PN: 84-871)*

GENERAL INSTRUCTIONS _____

Control Locations _____

For a diagram of the Model 310-TEL, please refer to page 15.

Test Leads _____

Check the test leads periodically. Leads that are worn, have damaged insulation, damaged plugs, damaged probes or loose parts should be replaced.

The following section should be read carefully. It contains instructions and precautions to be observed in making measurements with the tester.

The alligator clips provided with the tester fit over the end of the test probes. When measuring high voltage, these alligator clips allow measurement without handling the test probes. ALWAYS SHUT OFF THE POWER source before attempting to connect alligator clips.

Range Selection _____

When the approximate value of the quantity being measured is not known, ALWAYS START ON THE HIGHEST RANGE. For greater accuracy, choose the range which will allow readings to be taken in the upper (right hand) portion of the scale. See Operation Chart on page 26.

Scale Selection _____

Readings are taken on the scale having the appropriate significant figures (both 3 and 300 volts are read on the 0-300 scale) by multiplying or dividing by a factor of 10 or 100 as indicated by the range/scale ratio (i.e., on the 3 volt range, divide the scale readings by 100). See Operation Chart on page 26.

Polarity Selection _____

The Polarity Reversing Switch allows the user to electrically reverse the test lead connections. That is, when the user mistakenly connects the test leads to a circuit and obtains a "downscale" reading, the Polarity Reversing Switch may be operated to obtain an "upscale" reading.

The Switch may also be operated in the Ohms ranges to observe "forward" and "reverse" resistance of a circuit, or to observe the "capacitive kick" of a circuit.

Changing Settings _____

The test probes should be disconnected from the voltage source (or the source shut off) before the Range Switch or Polarity Reversing Switch position is changed. This practice will result in an increased life and reliability for the tester, as well as establishing a good safety practice.

Zero Adjustment _____

The Meter Zero Adjust Screw is located near the center of the tester. It should be periodically adjusted so the meter pointer is on zero with no input into the tester.

Other Considerations _____

Readings on the sensitive voltage, current and resistance ranges may sometimes be different than calculated values. Thermo-electric or electro-chemical reactions can sometimes generate voltage (and current) in a circuit due to elevated temperatures, contact of dissimilar metals, chemical fumes or moisture. Also, the user's fingers should never touch the metal parts of the test probes since body resistance can cause erroneous readings - particularly on the high ohmmeter ranges.

Care _____

Although this instrument is portable and rugged, it should be treated with care. Do not drop it or handle it roughly.

Avoid placing it on a bench where machine tools are used or severe vibration is encountered.

When possible, keep it in a place of moderate temperature. Avoid subjecting it to extreme temperatures and severe temperature changes.

If the tester has not been used for a long period of time, rotate the switch in both directions several times to clean the switch contacts.

CONTROL LOCATION DIAGRAM

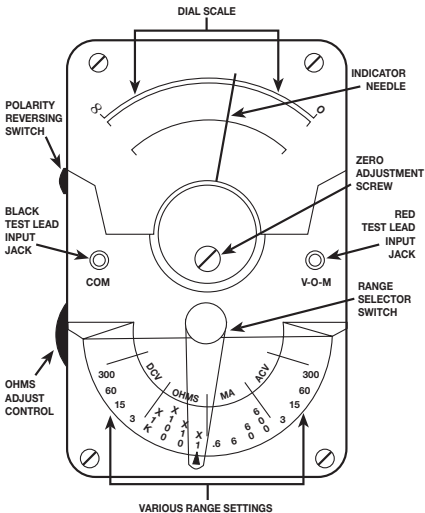

DC VOLTAGE MEASUREMENTS

0-3 through 0-300 Volts:

- 1. Insert the test leads into the appropriate jacks.
(Red to V•O•M, Black to COM)*
- 2. Set Range Switch to appropriate DCV range.*
- 3. Set the Polarity Switch to desired polarity.*
- 4. Connect probes across circuit to be measured.*
- 5. Energize circuit.*
- 6. Read voltage on the black AC-DC scale.*

***DO NOT TOUCH THE VOM while
it is connected to high voltage!***

DC VOLTAGE MEASUREMENTS

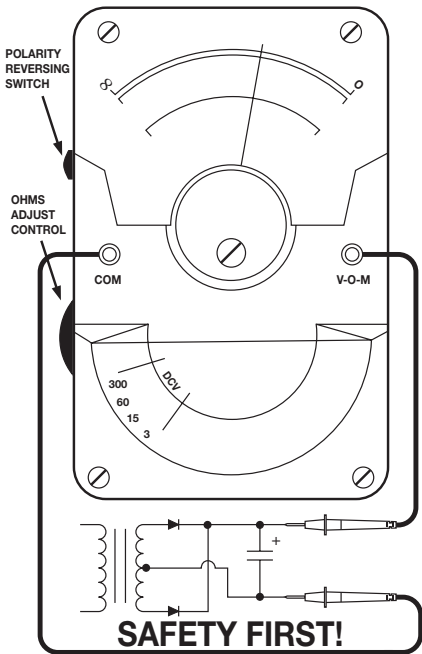

AC VOLTAGE MEASUREMENTS

0-3 through 0-300 Volts:

- 1. Insert the test leads into the appropriate jacks.
(Red to V•O•M, Black to COM)*
- 2. Set Range Switch to appropriate ACV range.*
- 3. Connect probes across circuit to be measured.*
- 4. Energize circuit.*
- 5. Read voltages above 3 Volts on the Black AC-DC Scale. Read voltages below 3 Volts on the Red 3AC Scale (with the VOM set to 3ACV).*

***DO NOT TOUCH THE VOM while
it is connected to high voltage!***

AC VOLTAGE MEASUREMENTS

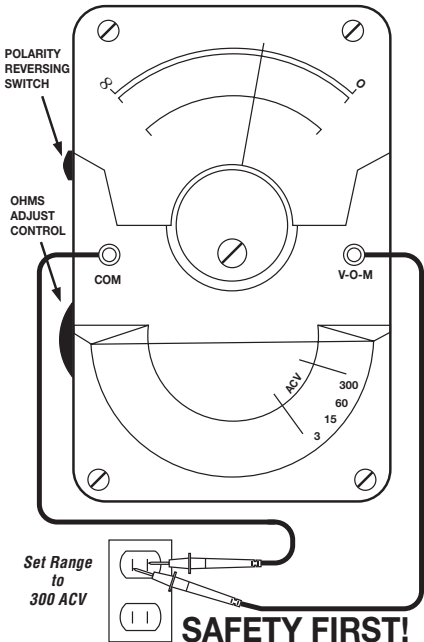

RESISTANCE MEASUREMENTS

X1 through X1K Ohms:

- 1. Insert the test leads into the appropriate jacks. (Red to V•O•M, Black to COM)*
- 2. Set Range Switch to appropriate OHMS range.*
- 3. Short test probes together.*
- 4. Adjust OHMS ADJUST CONTROL until meter reads zero ohms.*
- 5. Connect probes to the circuit or component to be measured.*
- 6. Read ohms on OHMS scale (multiply value read by multiplier indicated by the switch).*
- 7. Operate Polarity Switch to observe “forward” and “reverse” resistance of the circuit or component. If appropriate, observe the “capacitive kick” of the circuit or component as the Polarity Switch is operated.*

A fuse protects the X1 range against accidental overloads. If the fuse should blow, all OHMS ranges will not operate.

DO NOT TOUCH circuitry while making measurements.

DISCONNECT or ISOLATE the device being tested from other circuitry.

NOTE: 1K equals 1000.

RESISTANCE MEASUREMENTS

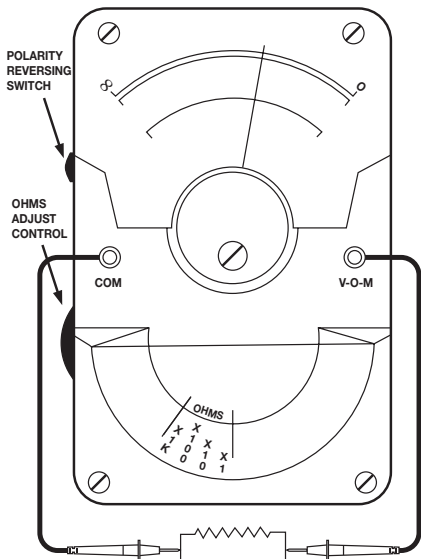

SAFETY FIRST!

DC CURRENT MEASUREMENTS

0-.6 through 0-600 Milliampere:

- 1. Insert the test leads into the appropriate jacks.
(Red to V•O•M, Black to COM)*
- 2. Set Range Switch to appropriate mA range.*
- 3. Connect the probes in series with the circuit to be measured (use alligator clips).*
- 4. Set the Polarity Switch to desired polarity.*
- 5. Turn circuit on.*
- 6. Read current on appropriate black AC-DC scale.*

The approximate voltage drop (burden voltage) across the Model 310-TEL is shown in the specifications. Generally, this drop will not affect the circuit. But, in low voltage circuits, it may be necessary to compensate for this drop.

***DISCONNECT POWER before connecting
the Model 310-TEL into the circuit.***

DC CURRENT MEASUREMENTS

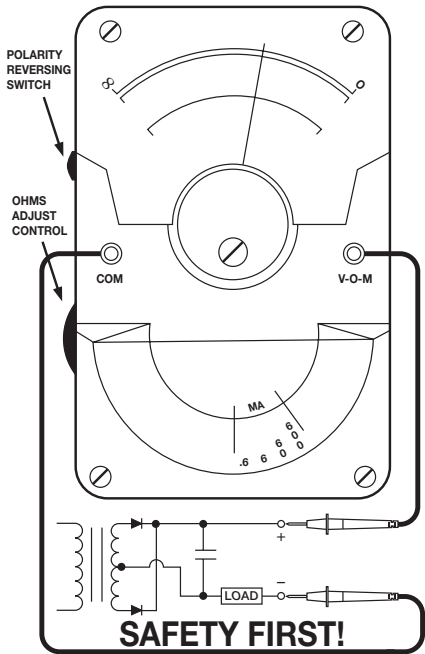

MEASURING OUTPUT VOLTS (dB)

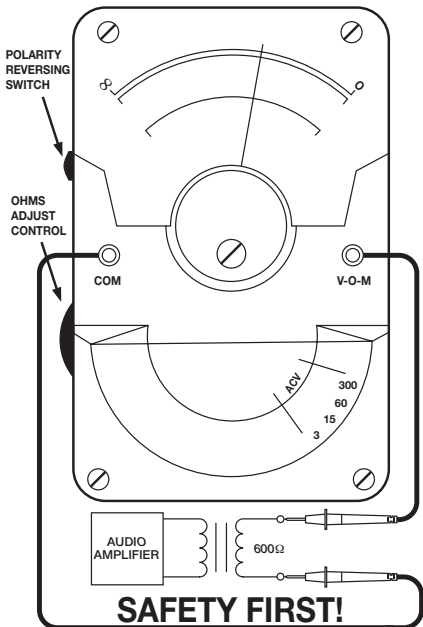

SAFETY FIRST!

To read Output Voltage use the same procedure as shown on page 18 for AC Voltage and convert readings to dB using the chart on page 25.

MEASURING OUTPUT VOLTS (dB)

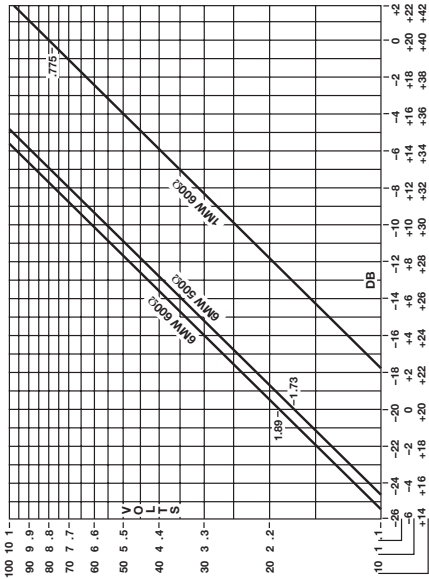

310-TEL OPERATION CHART

| To Measure | Range | Set Switch To | Read On Scale | Each Scale Div. Equals |
|-----------------|-------------|---------------|----------------|------------------------|
| DC Volts | 0 - 3 | DCV 3 | 300 + 100 | .05 Volt |
| | 0 - 15 | DCV 15 | 15 | .25 Volt |
| | 0 - 60 | DCV 60 | 60 | 1 Volt |
| | 0 - 300 | DCV 300 | 300 | 5 Volt |
| AC Volts | 0 - 3 | ACV 3 | 3AC | .05 Volt |
| | 0 - 15 | ACV 15 | 15 | .25 Volt |
| | 0 - 60 | ACV 60 | 60 | 1 Volt |
| | 0 - 300 | ACV 300 | 300 | 5 Volt |
| Ohms | 0 - 20,000 | OHMS X1 | 0 - 20K | |
| | 0 - 200,000 | OHMS X10 | 0 - 20K x 10 | |
| | 0 - 2 Meg | OHMS X100 | 0 - 20K x 100 | |
| | 0 - 20 Meg | OHMS X1K | 0 - 20K x 1000 | |
| DC mA | 0 - .6 | MA .6 | 60 + 100 | .01 mA |
| | 0 - 6 | MA 6 | 60 + 10 | .1 mA |
| | 0 - 60 | MA 60 | 60 | 1 mA |
| | 0 - 600 | MA 600 | 60 x 10 | 10 mA |

NOTE: Connect the Black Test Lead to the COM Jack and the Red Test Lead to the V•O•M Jack.

ACCESSORIES

Carrying Cases:



**Model 369:
Cat. No. 10-1258**



**Model 369-S:
Cat. No. 10-1791**



**Model 369-T:
Cat. No. 10-1608**



**Case w/ Belt Loop:
Cat. No. 10-1269**



**Model 369-V:
Cat. No. 10-2959**

Test Leads:

79-153: 42" Test leads w/Screw-on Alligator Clips

79-206: 48" Test leads with Alligator Clips (no probes)

79-695: Test leads with Pin Cushion Clips

79-722: Test leads with Spike Clips

MAINTENANCE FOR MODEL 310-TEL _____

Battery Replacement

If the pointer cannot be adjusted to full scale on the X1, X10, or X100 OHMS ranges, replace the 1.5V battery. Replace the 12V battery if the X1K OHMS range cannot be adjusted for full scale.

1.5V Battery - NEDA 910F or 910M (PN: 37-21)

12V Battery - A23 (PN: 37-60)

Fuse Replacement

If none of the OHMS ranges work, replace the fuse. Use a 1/16 AMP, 5 mm x 20 mm fuse. (PN: 3207-112)

Cleaning Plastic Window

The plastic window has been treated at the factory to dissipate static charges. If cleaning is necessary use cotton dipped in a solution of common household detergent and water. After cleaning, allow the solution to dry without rubbing; the resultant detergent film will effectively dissipate static charges.

CAUTION:

Solvents and liquids used in radio and TV shop work may craze or scar the plastic window if applied to it.

Calibration

With normal use, readjustment of this VOM should not be necessary. An occasional check of the VOM against a known reference voltage or another VOM is good practice. If there is a question about the accuracy of the VOM, it should be returned to the factory or an authorized service center for a calibration check.

TRIPLETT PRODUCT RETURN INSTRUCTIONS

In the unlikely event that you must return your Triplet equipment for repair, the following steps must be taken.

- 1) Call 1-800-TRIPLETT to obtain a Return Material Authorization (RMA) number from Customer Service.***
- 2) Enclose a copy of the original sales receipt showing date of purchase.***
- 3) Clearly print the RMA number on the outside of the shipping container.***
- 4) Return to:***
Triplet Corporation
One Triplet Drive
Bluffton, OH 45817
ATTN: Repair Dept.

Be sure to include a full description of the problem, and a telephone number, street address, or email address, where you can be contacted, and a return address where the meter can be shipped to upon repair.

TRIPLETT LIMITED WARRANTY _____

The Triplett Corporation warrants instruments and test equipment manufactured by it to be free from defective material or workmanship and agrees to repair or replace such products which, under normal use and service, disclose the defect to be the fault of our manufacturing, with no charge within three years of the date of original purchase for parts and labor. If we are unable to repair or replace the product, we will make a refund of the purchase price. Consult the Instruction Manual for instructions regarding the proper use and servicing of instruments and test equipment. Our obligation under this warranty is limited to repairing, replacing, or making refund on any instrument or test equipment which proves to be defective within three years (one year on calibration) from the date of original purchase.

This warranty does not apply to any of our products which have been repaired or altered by unauthorized persons in any way so as, in our sole judgment, to injure their stability or reliability, or which have been subject to misuse, abuse, misapplication, negligence, accident or which have had the serial numbers altered, defaced, or removed. Accessories, including batteries and fuses, not of our manufacture used with this product are not covered by this warranty.

To register a claim under the provisions of this warranty, return the instrument or test equipment to Triplett Corporation, Bluffton, Ohio 45817, transportation prepaid. Upon our inspection of the product, we will advise you as to the disposition of your claim.

ALL WARRANTIES IMPLIED BY LAW ARE HEREBY LIMITED TO A PERIOD OF ONE YEAR AND THE PROVISIONS OF THE WARRANTY ARE EXPRESSLY IN LIEU OF ANY OTHER WARRANTIES EXPRESSED OR IMPLIED.

The purchaser agrees to assume all liability for any damages and bodily injury which may result from the use or misuse of the product by the purchaser, his employees, or others, and the remedies provided for in this warranty are expressly in lieu of any other liability Triplett Corporation may have, including incidental or consequential damages.

Some states (USA ONLY) do not allow the exclusion or limitation of incidental or consequential damages, so the above limitation or exclusion may not apply to you. No representative of Triplett Corporation or any other person is authorized to extend the liability of Triplett Corporation in connection with the sale of its products beyond the terms hereof.

Triplett Corporation reserves the right to discontinue models at any time, or change specifications, price or design, without notice and without incurring any obligation.

This warranty gives you specific legal rights, and you may have other rights which vary from state to state.

**TRIPLETT CORPORATION
BLUFFTON, OHIO
1-800-874-7538
www.triplett.com**

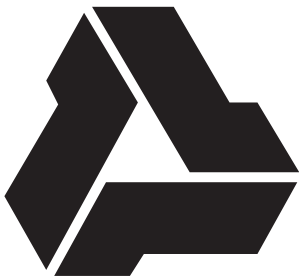

TRIPLETT

Triplett Corporation One Triplett Drive Bluffton, OH 45817
800-TRIPLETT FAX: 419-358-7956 www.triplett.com

© Triplett Corporation

All Rights Reserved